

27" HD Touchscreen Medical Display

FS-L2702DT



FS-L2702DT is a projected capacitive multi-touch screen that is designed for medical applications including endoscopy, fluoroscopy, and ultrasound. The touchscreen offers ultimate data and image control for clinicians. It features a high brightness LED back light and rich color calibration set to Rec. 709 (sRGB gamut) for HD medical grade image consistency. FSN's complete set of monitor features are designed specifically for presenting images from surgical endoscopic camera systems or other medical imaging devices.



User Friendly

FS-L2702DT incorporates an intuitive, full- featured on screen menu for image and layout settings. Multi-modality options let doctors view two images



at the same time. Its lightweight design is ideal for boom or spring-arm mounting, and the convenient back cable cover helps organize and manage multiple cords.

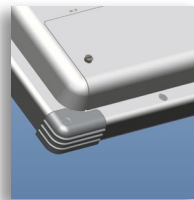

Designed for the OR

The unique exterior of FS-L2702DT is comprised of a slim and sleek housing design, built in rounded corner bumpers for added safety, and sturdy construction that withstands the rigors of daily OR use. Edge-to-edge front glass allows for fast disinfection and quick surgery room turnaround. Ingress protection rating of 33 helps protect internal components against solid or liquid contamination. The monitor's back cover offers input/output port protection and clean cable management.

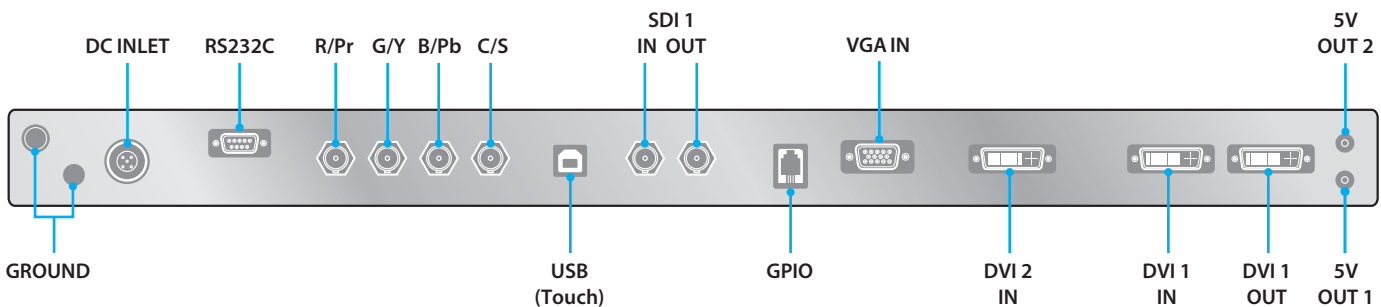

www.fsnmed.com

Foreseeson Custom Displays, Inc.
2210 E. Winston Road
Anaheim, CA 92806 USA
Tel: 714-300-0540
Fax: 714-300-0546

San Jose, CA Tel: 714-507-3851
Fort Lee, NJ Tel: 714-507-3852

Foreseeson Korea
404B, PangyoInnovalley B
253 Pangyo-ro
Bundang-gu Seongnam-si
Gyeonggi-do, Korea 463-400
Tel: +82-31-8018-0780
Fax: +82-31-8018-0786

Foreseeson GmbH
Industriestrasse 38a
63150 Heusenstamm, Germany
Tel: +49 6104 64398 0
Fax: +49 6104 64398 11

Foreseeson UK Ltd.
Unit 71 Barwell Business Park
Leatherhead Road
Cheshington, Surrey KT9 2NY
Tel: +44 (0) 208 546 1047

Foreseeson (Shanghai)
Medical Equipment Co., Ltd.
Room 307, 3F
No. 56, 461 Hongcao Road
Caohejing Development District
Xuhui, Shanghai 200233
Tel: 86-21-6113-4188

27" HD Medical Display

FS-L2702DT



Specifications

General Features

Item	Description
Panel	27 inch TFT LCD (LED)
Resolution	1920 x 1080 pixel
Aspect Ratio	16 : 9
Active Area	597.89 (H)mm x 336.31 (V)mm
Touchscreen	Projected Capacitive USB
Pixel Pitch (mm)	0.3114 x 0.3114
Response Time (typical)	14 ms (gray to gray)
Number of Colors	1.07 Billion
Brightness (typical)	800 cd/m ²
Contrast Ratio (typical)	1000 : 1
Surface Treatment	Anti-glare
Viewing Angle (CR>10)	R/L 178°, U/D 178°

Item	Description
Input Signal	2 x DVI (single link) 1 x VGA 1 x Component 1 x SDI (3G)
Output Signal	1 x DVI (single link) 1 x SDI (3G)
Power Supply	AC/DC Adaptor (AC 100~240V, DC 24V/6.6A)
Power Consumption	100W
Accessories Included	User manual, AC-DC adaptor, AC power cord, DVI-D cable, BNC cable, USB cable, Screw BH M4 x 14
Unit Dimension	673(W) x 425(H) x 75.2(D) mm 26.49(W) x 16.73(H) x 2.96(D) inch
Package Dimension	755.65(W) x 654.05(H) x 234.95(D) mm 29.75(W) x 25.75(H) x 9.25(D) inch
IP Rating	IP33 - overall
Weight	9.09 kg, 20.04 lbs. (monitor with cover) 14.5 kg, 31.97 lbs. (shipping package)
Certifications	ANSI/AAMI ES60601-1(UL60601-1), CAN/CSA C22.2 No. 60601-1, FCC Class B, EN60601-1, EN60601-1-2, CE, MDD(93/42/EEC) Class I Medical Device

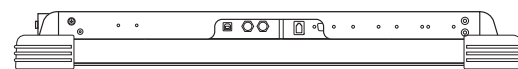
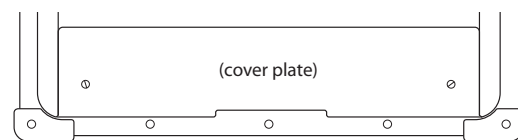
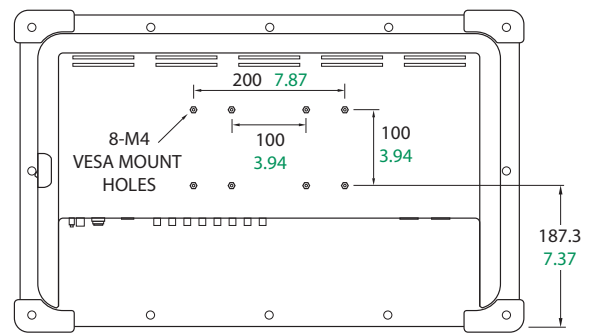
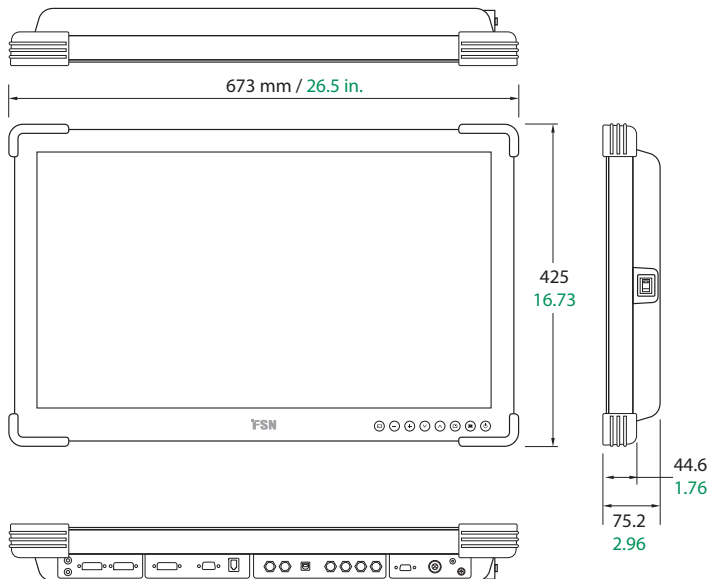

FSN Medical Technologies products meet RoHS2 and Registration, Evaluation, Authorisation and Restriction of Chemicals (REACH) obligations. FSN manages the information flow as required by regulations.

Specifications are subject to change with or without notice. Doc.# FSN2002 Rev. 12/18

www.fsnmed.com

Foreseeson Custom Displays, Inc.
2210 E. Winston Road
Anaheim, CA 92806 USA
Tel: 714-300-0540
Fax: 714-300-0546

San Jose, CA Tel: 714-507-3851
Fort Lee, NJ Tel: 714-507-3852

Foreseeson Korea
404B, PangyoInnovalley B
253 Pangyo-ro
Bundang-gu Seongnam-si
Gyeonggi-do, Korea 463-400
Tel: +82-31-8018-0780
Fax: +82-31-8018-0786

Foreseeson GmbH
Industriestrasse 38a
63150 Heusenstamm, Germany
Tel: +49 6104 64398 0
Fax: +49 6104 64398 11

Foreseeson UK Ltd.
Unit 71 Barwell Business Park
Leatherhead Road
Chessington, Surrey KT9 2NY
Tel: +44 (0) 208 546 1047

Foreseeson (Shanghai)
Medical Equipment Co., Ltd.
Room 307, 3F
No. 56, 461 Hongcao Road
Caohejing Development District
Xuhui, Shanghai 200233
Tel: 86-21-6113-4188